

MOTOROLA

Semiconductor Technical Data

Advance Information

Automotive Dual High Side Switch

The MC33289DW is a Dual High Side Switch (DHSS) dedicated for use in automotive applications. It is designed to drive typical inductive loads such as solenoid valves.

This device consists of two independent 40mOhm R_{dson} MOSFET channels plus corresponding control circuitry in a surface mount package. The MC33289DW can be interfaced directly to a microcontroller for input control and monitoring of diagnostic output.

Each switch offers independent protection and diagnosis during overcurrent, overvoltage, and undervoltage conditions, as well as an overtemperature shutdown feature.

A logic low on the Open Load Detect Enable pin (OLDE) minimizes bias current drain by disabling the open load circuitry current source. The device also has a very low quiescent current in standby mode.

- Designed to drive Automotive Inductive loads
- Junction Temperature Range from -40°C to 150°C
- Operating Voltage Range from 6V to 27V
- Maximum Breakdown Voltage greater than 40V
- Surface Mount Package
- $40\text{m}\Omega$ R_{dson} at 25°C
- Overtemperature Protection with Hysteresis
- Overcurrent protection
- Under Voltage Shutdown
- Over Voltage Shutdown
- Open Load Detection in Off-State
- Independent Diagnostic Output
- ESD Protection 2kV
- Standby Current less than $5\mu\text{A}$ at V_{bat} below 14V

MC33289

AUTOMOTIVE DUAL HIGH SIDE SWITCH

SEMICONDUCTOR
TECHNICAL DATA

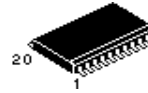

DW SUFFIX
SO20WB Package
CASE 751D-05

PIN ASSIGNMENT

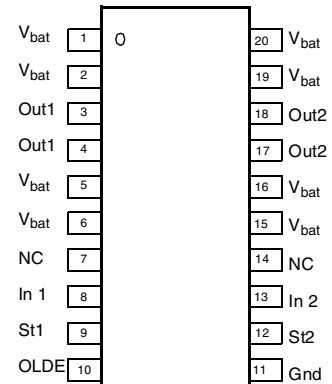

ORDERING INFORMATION

Device	Operating Temperature Range	Package
PC33289DW	TA= -40° to $+125^{\circ}\text{C}$	SO20

Simplified Application Schematic

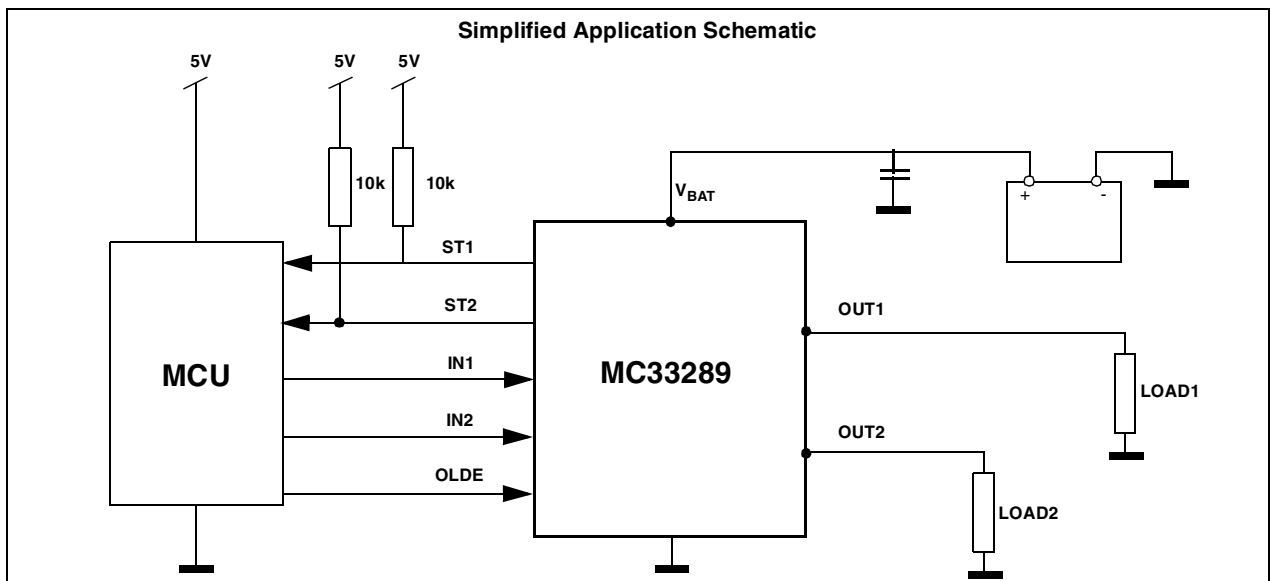

This document contains information on a new product. Specifications and information herein are subject to change without notice.

PINS FUNCTION DESCRIPTION

Pin No.	Name/Function	Description
1, 2, 5, 6, 15, 16, 19, 20	V _{bat} Supply Voltage	These are the power supply pins of the device. These pins are directly connected with the lead frame of the package and are tied to the drain of the switching MOSFET. These pins can be directly connected to the battery voltage. In addition to their supply function, these pins participate to the thermal behaviour of the device in conducting the heat from the switching MOSFET to the printed circuit board.
3, 4, 18, 17	OUT1 OUTPUT Channel 1 OUT 2 OUTPUT Channel 2	Pins 3 and 4 are the output 1 terminals. Pins 17 and 18 are the output 2 terminals. They are directly connected to the source of the power MOSFET. These pins are used by the control circuitry to sense the device output voltage. The R _{dson} is 40mΩ max per output at 25°C and will increase to a maximum of 75mΩ at 150°C junction temperature.
8, 13	IN 1 INPUT Channel 1 IN 2 INPUT Channel 2	These are the device input pins which directly control their associated outputs. The levels are CMOS compatible. When the input is a logic low, the associated output MOSFET is in the off state. When input is high, the MOSFET is turned on and the load is activated. When both inputs are low, the device is in standby mode and its supply current is reduced. Each input pin has an internal active pull down, so that it will not float if disconnected.
9, 12	St1 Status for Channel 1 St2 Status for Channel 2	These pins are the channel 1 and channel 2 fault detection flags. Their internal structure is an open drain architecture with an internal clamp at 6V. An external pull up resistor connected to V _{dd} (5V) is needed. This is an active low output. If the device is in its normal condition the status lines will be high. If open load or other fault occurs, the associated channel' status flag will be pulled low. See Functional Truth Table.
10	OLDE Open Load Detection Enable	This pin is a digital input which enables the open load current diagnostic circuitry. When OLDE is a logic low, the open load circuitry is not powered and the device's bias current draw is at a minimum. If OLDE is a logic high, the open load circuitry is functional at the price of a higher bias current draw. OLDE pin has a pull down resistor.
11	GND GROUND	This is the Gnd pin of the device.

Block Diagram And Typical Application

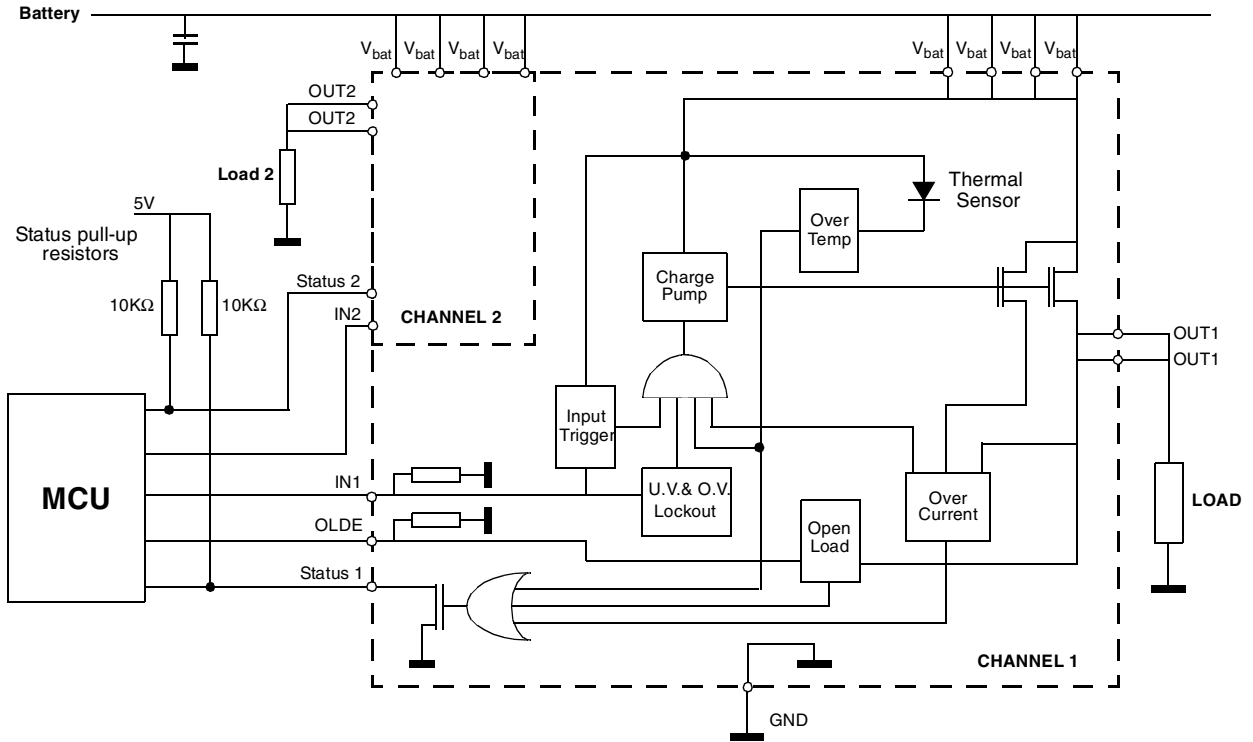

FUNCTIONAL TRUTH TABLE

Conditions	IN1	IN2	OUT1	OUT2	St1	St2
Normal Operating Conditions	L	L	L	L	H	H
	H	L	H	L	H	H
	L	H	L	H	H	H
	H	H	H	H	H	H
Overtemperature Channel 1	H	X	L	X	L	H
Overtemperature Channel 2	X	H	X	L	H	L
Overtemperature Channel 1/Channel 2	H	H	L	L	L	L
Open Load Channel 1	L	X	H	X	L	H
Open Load Channel 2	X	L	X	H	H	L
Overcurrent Channel 1	H	X	L	X	L	H
Overcurrent Channel 2	X	H	X	L	H	L
Undervoltage Condition	X	X	L	L	H	H
Overvoltage Condition	X	X	L	L	H	H

L = 'Low level' ; H = 'High level' ; X = 'don't care'

MAXIMUM RATINGS

Ratings	Symbol	Value	Unit
V _{bat} and V _{batc} Voltage : Continuous/Pulse	V _{bat}	-0.3 to 41	V
OUT1, OUT2 Voltage with Respect to Gnd : Continuous/Pulse	V _{out}	-4 to 41	V
OUT1, OUT2 to V _{btap} Voltage : Continuous	V _{out}	41	V
St1, St2 Voltage : Continuous/Pulse	V _{st}	-0.3 to 7	V
IN1, IN2 Voltage : Continuous	V _{in}	-0.3 to 7	V
In1, In2, St1, St2, OLDE Current	I _{in}	+/-4	mA
ESD all Pins Human Body Model (note1)	V _{esd1}	+/-2000	V
Machine Model (note2)	V _{esd2}	+/-200	V

NOTES : 1. EDS1 testing is performed in accordance with the Human Body Model (Czap = 100pF, Rzap = 1500Ω)
2. EDS2 testing is performed in accordance with the Machine Model (Czap = 100pF, Rzap = 0Ω)

THERMAL RATINGS

	Symbol	Value	Unit
Operating Junction Temperature	T _j	-40 to 150	°C
Storage Temperature	T _{st}	-55 to 150	°C
Thermal Resistance Junction to Ambient (note 1)	R _{thja}	70	°C/W
Thermal Resistance Junction to lead : Both Channel on	R _{thjl1}	15	°C/W
Thermal Resistance Junction to lead : One Channel on	R _{thjl2}	15	°C/W
Thermal Resistance Junction to lead : Logic Die	R _{thjl3}	30	°C/W

NOTES : 1. with minimum PCB dimensions.

ELECTRICAL CHARACTERISTICS T_j from -40°C to +150°C, V_{bat} from 6V to 24V, unless otherwise noted. Typical values reflect approximate mean at 25°C, nominal V_{bat}, at time of device characterization.

Description	Symbol	Characteristics			Unit	Conditions
		Min	Typ	Max		
STATIC CHARACTERISTICS						
Operating Voltage	V _{bat}	6		V _{ov}	V	
Supply Current : Both Channels On	I _{bat1}		6	16	mA	V _{bat} = 13.5V ; OLDE High
Supply Current : One Channel On	I _{bat2}		5	10	mA	V _{bat} = 13.5V ; OLDE High
Supply Current : Both Channels Off	I _{bat3}			5	μA	V _{bat} = 12.6V ; OLDE Low, T _j <125°C
Supply Current : Any State	I _{bat_max}			30	mA	V _{bat} = 13.5V
Output Off state leakage current per channel	I _{DSS}		0.1	5	μA	V _{bat} =13.5V; IN1,2,Olde low, Both ourput grounded, T _j <125°C
Drain-Source On Resistance	R _{dson1}			40	mΩ	V _{bat} >10V, T _{amb} =25°C
Drain-Source On Resistance	R _{dson2}			75	mΩ	V _{bat} >10V, T _{amb} =150°C
Negative Inductive Clamp Voltage	V _{clamp}	-4		-1	V	I _{OUT} = 1A
INPUT CHARACTERISTICS						
High Input Voltage (IN1, IN2)	V _{ih}	3.25			V	
High Input Voltage (OLDE)	V _{OLDEH}	3.5			V	
Low Input Voltage (IN1, IN2, OLDE)	V _{il}			1.5	V	
Logic Input Hysteresis IN1, IN2	V _{hyst}	0.4	0.6	0.8	V	

ELECTRICAL CHARACTERISTICS T_j from -40°C to +150°C, V_{bat} from 6V to 24V, unless otherwise noted. Typical values reflect approximate mean at 25°C, nominal V_{bat} , at time of device characterization.

Description	Symbol	Characteristics			Unit	Conditions
		Min	Typ	Max		
Logic Input Current	I_{in}	3			μA	$V_{in} = 1.5V$
Logic Input Current	I_{in}			32.5	μA	$V_{in} = 3.25V$
Logic Input Clamp Voltage	V_{clamp}	5.5		7	V	At $I_{in} = 1mA$
Input Capacitance IN1, IN2	C_{in}			80	pF	$R_{in} = 47k\Omega @ 100kHz$
STATUS CHARACTERISTICS						
Status Voltage	V_{st}			0.5	V	$I_{st} = 1mA$; Output in fault
Status Leakage Current	I_{stlk}			10	μA	$V_{st} = 5V$
Status Pin Capacitance	C_{st}			80	pF	$V_{st} = 5V$
OVERLOAD PROTECTION CHARACTERISTICS						
Overcurrent latchoff threshold	I_{OCT}	4		9	A	$V_{Bat} = 13.5V$
Overcurrent latchoff delay	T_{OCTDLY}			30	μs	From OverCurrent Tresh- old achieved to Ouput Volt- age= 10%Vbatt
Overcurrent latchoff status delay	$T_{OCTST-DLY}$			50	μs	From Ouput Voltage= 10%Vbatt to Status Flag<1V
Thermal Shutdown	T_{shut}	150	165	175	$^{\circ}C$	
Thermal Shutdown Hysteresis	T_{hyst}			10	$^{\circ}C$	
Overvoltage Shutdown Threshold	V_{ov}	27		38	V	Both IN1, IN2 logic high
Overvoltage Shutdown Hysteresis	V_{ovhyst}	0.1		2	V	Both IN1, IN2 logic high
Undervoltage Shutdown Threshold	V_{uv}	4.75		6	V	Both IN1, IN2 logic high
Undervoltage Shutdown Hysteresis	V_{uvhyst}	0.3	0.6	1	V	Both IN1, IN2 logic high
OPEN CIRCUIT DETECTION CHARACTERISTICS						
Open Load Detect Current	I_{OL}	200	290	400	μA	$V_{out} = 3.5V$, OLDE = 4V
Open Load Threshold Voltage	V_{OL}	1.5	2.4	3.5	V	
Open Load to Status Low Delay Time	T_{OLSTDT}			100	μs	From IN=1.5 to Status Flag<1.5V
Open Load Detect BlankingTime	T_{OLDBT}	3	10	50	μs	From IN=1.5 to Openload circuitry enable
Openload threshold voltage	V_{inOL}	1.5	2.5	3.5	V	
SWITCHING CHARACTERISTICS (8V < V_{bat} < 18V, R_{load} =7Ohms)						
Turn On Slew Rate	S_{rpout1}	1		20	V/ μs	From 10% to V_{Bat} -3V,
Turn On Slew Rate	S_{rpout2}	0.1		3	V/ μs	From V_{bat} -3V to 90%,
Turn Off Slew Rate	S_{rmout}	1		20	V/ μs	From 90% to 10%,
Turn-on Delay Time	t_{don}	1	2.5	15	μs	From $V_{IN}/2$ to 10% V_{bat} ,
Turn-off Delay Time	t_{doff}	1	5	15	μs	From $V_{IN}/2$ to 90% V_{bat} ,

Motorola reserves the right to make changes without further notice to any products herein. Motorola makes no warranty, representation or guarantee regarding the suitability of its products for any particular purpose, nor does Motorola assume any liability arising out of the application or use of any product or circuit, and specifically disclaims any and all liability, including without limitation consequential or incidental damages. "Typical" parameters which may be provided in Motorola data sheets and/or specifications can and do vary in different applications and actual performance may vary over time. All operating parameters, including "Typical" must be validated for each customer application by customer's technical experts. Motorola does not convey any license under its patent rights nor the rights of others. Motorola products are not designed, intended, or authorized for use as components in systems intended for surgical implant into the body, or other applications intended to support or sustain life, or for any application in which the failure of the Motorola product could create a situation where personal injury or death may occur. Should Buyer purchase or use Motorola products for any such unintended or unauthorized application, Buyer shall indemnify and hold Motorola and its officers, employees, subsidiaries, affiliates, and distributors harmless against all claims, costs, damages, and expenses, and reasonable attorney fees arising out of, directly or indirectly, any claim of personal injury or death associated with such unintended or un authorized use, even if such claim alleges that Motorola was negligent regarding the design or manufacture of the parts. Motorola and  are registered trademarks of Motorola, Inc. Motorola, Inc. is an Equal Employment Opportunity/Affirmative Action Employer.

How to reach us:

USA / EUROPE / Locations Not Listed: Motorola Literature Distribution;
P.O. Box 5405, Denver, Colorado 80217. 1-303-675-2140 or 1-800-441-2447

JAPAN: Motorola Japan Ltd.; SPS, Technical Information Center, 3-20-1,
Minami-Azabu, Minato-ku, Tokyo 106-8573 Japan. 81-3-344-3569

Technical Information Center: 1-800-521-6274

ASIA / PACIFIC: Motorola Semiconductors H.K. Ltd.; Silicon Harbour Centre,
2, Dai King Street, Tai Po Industrial Estate, Tai Po, N.T., Hong Kong.
852-26668334

HOME PAGE: <http://www.motorola.com/semiconductors>



MC33289/D

SUNSTAR 商斯达实业集团是集研发、生产、工程、销售、代理经销、技术咨询、信息服务等为一体的高科技企业，是专业高科技电子产品生产厂家，是具有 10 多年历史的专业电子元器件供应商，是中国最早和最大的仓储式连锁规模经营大型综合电子零部件代理分销商之一，是一家专业代理和分销世界各大品牌 IC 芯片和电子元器件的连锁经营综合性国际公司，专业经营进口、国产名厂名牌电子元件，型号、种类齐全。在香港、北京、深圳、上海、西安、成都等全国主要电子市场设有直属分公司和产品展示展销窗口门市部专卖店及代理分销商，已在全国范围内建成强大统一的供货和代理分销网络。我们专业代理经销、开发生产电子元器件、集成电路、传感器、微波光电元器件、工控机/DOC/DOM 电子盘、专用电路、单片机开发、MCU/DSP/ARM/FPGA 软件硬件、二极管、三极管、模块等，是您可靠的一站式现货配套供应商、方案提供商、部件功能模块开发配套商。商斯达实业公司拥有庞大的资料库，有数位毕业于著名高校——有中国电子工业摇篮之称的西安电子科技大学（西军电）并长期从事国防尖端科技研究的高级工程师为您精挑细选、量身订做各种高科技电子元器件，并解决各种技术问题。

更多产品请看本公司产品专用销售网站：

商斯达中国传感器科技信息网：<http://www.sensor-ic.com/>

商斯达工控安防网：<http://www.pc-ps.net/>

商斯达电子元器件网：<http://www.sunstare.com/>

商斯达微波光电产品网：[HTTP://www.rfoe.net/](http://www.rfoe.net/)

商斯达消费电子产品网：<http://www.icasic.com/>

商斯达实业科技产品网：<http://www.sunstars.cn/>

传感器销售热线：

地址：深圳市福田区福华路福庆街鸿图大厦 1602 室

电话：0755-83370250 83376489 83376549 83607652 83370251 82500323

传真：0755-83376182 (0) 13902971329 MSN: SUNS8888@hotmail.com

邮编：518033 E-mail:szss20@163.com QQ: 195847376

深圳赛格展销部：深圳华强北路赛格电子市场 2583 号 电话：0755-83665529 25059422

技术支持：0755-83394033 13501568376

欢迎索取免费详细资料、设计指南和光盘；产品凡多，未能尽录，欢迎来电查询。

北京分公司：北京海淀区知春路 132 号中发电子大厦 3097 号

TEL: 010-81159046 82615020 13501189838 FAX: 010-62543996

上海分公司：上海市北京东路 668 号上海赛格电子市场 2B35 号

TEL: 021-28311762 56703037 13701955389 FAX: 021-56703037

西安分公司：西安高新开发区 20 所(中国电子科技集团导航技术研究所)

西安劳动南路 88 号电子商城二楼 D23 号

TEL: 029-81022619 13072977981 FAX:029-88789382